

# TABLE OF DETAILS

Detail Number	Title
<b>Street Standard Details</b>	
410.01	Summary of Street Standards (2 Sheets)
410.02	Private Street (Curb & Gutter) (2 Sheets)
410.03	Standard Residential Street (2 Sheets)
410.04	Collector Street (2 Sheets)
410.05	Planned Industrial Street (Non-Curb & Gutter)
410.06	Standard Typical Section – Minor Thoroughfare
410.07	Standard Typical Section – Major Thoroughfare
411.01	Standard Curb & Gutter
411.02	Standard Roll-Type Curb and Gutter
411.03	Standard Catch Basin Frame 2'-0" in Curb and Gutter
411.04	Curb Transition – 2'-0" C&G to 2'-0" Roll Type C&G
411.05	Concrete Valley Gutter (2 Sheets)
411.06	Concrete Sidewalk
412.01	Standard Cul-De-Sac
412.02	Tangent Distances at Reverse Curves
412.03	Curve Radius at Deflecting Street Lines
412.04	Vertical Curve Design Table
414.01	Street Name Sign – 9" Sign Height
415.01	Dumpster Pad Detail
415.02	Recycling Center

# SUMMARY OF STREET STANDARDS

STREET CLASSIFICATIONS	CROSS SECTION	EASEMENT / ROW	PAVEMENT WIDTH (B/B)	AVERAGE DAILY TRAFFIC
PRIVATE STREET	CURB DITCH	40' EASEMENT 60' EASEMENT	28' 22'	< 1,500 < 1,500
STANDARD RESIDENTIAL	CURB DITCH	50' 60'	28' 22'	< 1,500 < 1,500
COLLECTOR	CURB DITCH	60' 70'	36' 34'	1,500 - 4,999 1,500 - 4,999
PLANNED INDUSTRIAL	DITCH	80'	28'	N/A
MINOR THOROUGHFARE	CURB	80'	65'	5,000 - 10,000
MAJOR THOROUGHFARE	CURB	100'+	VARIABLE	10,000 +
	<u>STD. C&amp;G</u>	<u>ROLL C&amp;G</u>	<u>NON CURB &amp; GUTTER</u> (outside urban core, single family only)	
MIN. LONGITUDINAL SLOPE	0.3%	0.5%	0.5% (channel flow line) 0.5% (street center line)	
MAX. DEPTH OF FLOW THOROUGHFARE NON-THOROUGHFARE	0.3 ft 0.5 ft	N/A 0.3 ft	N/A 2 ft	
MIN. DRIVEWAY CULVERT SIZE	N/A	N/A	15"	

## NOTES:

- The minimum longitudinal grade for channel sections may be reduced for cross drainage and at some isolated locations with the approval of the City Engineer. The City Engineer shall have the option of requiring piping for channels less than 0.8% slope.
- Minimum driveway separation along non-curb and gutter streets shall be 100 feet center to center as measured along the edge of pavement. A shared culvert configuration may be utilized pursuant to standards 422.01 thru 422.07, if the required spacing cannot be obtained.
- Driveways, along standard curb and gutter streets, shall conform to the Driveway Ordinance which requires removal of the complete section of the curb and gutter in lieu of breaking off the backs of curb.
- Driveway culvert sizes for each single family lot shall be determined at time of construction plan approval and shall be recorded on the final plat for each lot.
- The maximum 10-year storm headwater depth for driveway culverts shall not exceed 1.2D or the elevation of the driveway, whichever is less.
- All required channel linings and velocity control devices shall be designed and installed in accordance with the Soil Erosion and Sedimentation Control Ordinance and the North Carolina Erosion and Sediment Control Planning and Design Manual.
- Any street to be City-maintained shall have "Record Drawings" submitted and approved prior to scheduling of the pre-final street acceptance inspection. All "Record Drawings" for streets and storm drainage infrastructure shall include, but not necessarily limited to, the information as identified in the *Street and Storm Drainage "Record Drawings" Submittal Requirements*.



ENGINEERING DEPARTMENT  
Greenville, North Carolina 27834

**CITY OF GREENVILLE, N.C.** [www.greenvillenc.gov](http://www.greenvillenc.gov)

# SUMMARY OF STREET STANDARDS

Rev.	Date	Description	Approved
1	9/1/23	APPROVAL	L. KIRBY

Scale: not to scale	Sheet #: 1 of 2	Detail #: <b>410.01</b>
------------------------	--------------------	----------------------------

## **NOTES (CONTINUED):**

8. All concrete shall be cured with white pigmented curing compound in accordance with NCDOT Standards and Specifications.
9. Concrete testing in accordance with NCDOT Specifications is only required for structural concrete installed within or beneath the roadway. This includes but is not limited to bridge decks, box culverts, top slabs, and concrete paving. Testing is not required for sidewalks, valley gutter, and/or curb & gutter; however a copy of the load tickets for all concrete that is not tested shall be submitted to the City. Load tickets must specify mix design strength of concrete. The City reserves the right to conduct additional testing.
10. Right of Way Encroachment Agreement is required for mail kiosks within the right of way.
11. Mail kiosks are prohibited on minor and major thoroughfares unless off street parking is provided. Mail kiosks installed on residential streets require installation of "No Parking" signs on opposite side of street from mail kiosk (not required for collector streets).
12. Street lights shall be installed in accordance with the Lighting Standards for the City of Greenville.
13. All pavement markings shall be thermoplastic in accordance with NCDOT Standard Specifications for Roads and Structures.
14. Curb ramps shall be installed in accordance with NCDOT Standard Specifications for Roads and Structures and NCDOT Roadway Standard Drawings (latest editions). All ramps shall comply with applicable portions of the Americans with Disabilities Act and the U.S. Access Board Public Rights-of-Way Accessibility Guidelines.
15. Street standards are applicable to both public and private streets.
16. Parking is prohibited on both sides of dead end streets which do not require the installation of a cul de sac or temporary turn around. "No Parking" signs shall be shown on construction plans and installed by the developer prior to street acceptance.
17. Maintenance of temporary turn arounds is the responsibility of the developer or Homeowner's Association and a note stating such shall be included on the final plat.



ENGINEERING DEPARTMENT  
Greenville, North Carolina 27834

**CITY OF GREENVILLE, N.C.**

[www.greenvillenc.gov](http://www.greenvillenc.gov)

Rev.	Date	Description	Approved
1	9/1/23	APPROVAL	L. KIRBY

## **SUMMARY OF STREET STANDARDS**

Scale:  
not to scale

Sheet #:  
2 of 2

Detail #:  
**410.01**

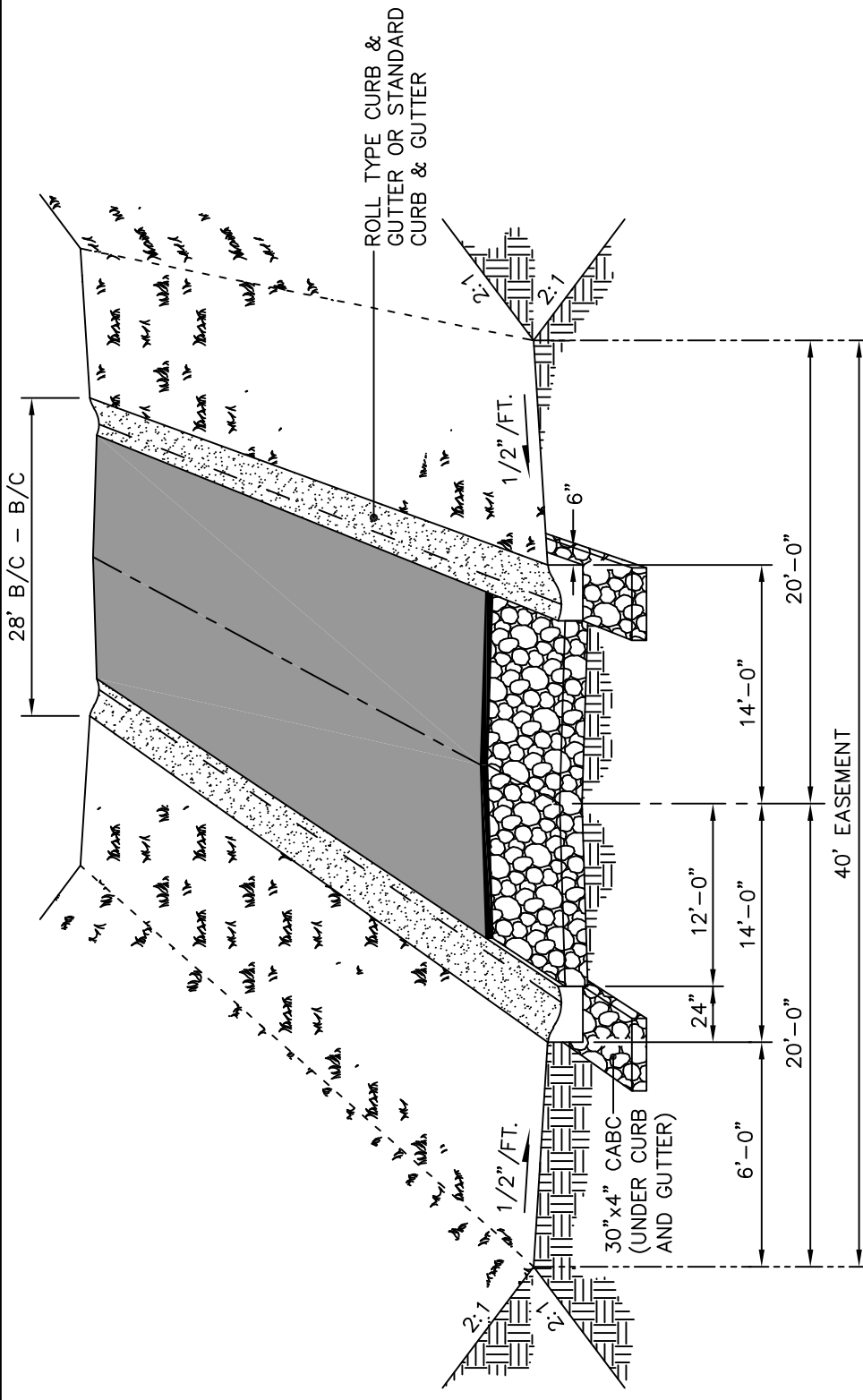

**TYPICAL CROSS SECTION**  
 "PRIVATE STREET"  
 (CURB & GUTTER)

**NOTES:**

1. Pavement design to be according to procedure described in Std. detail No. 490.01.
2. May only be used in cases where projected traffic volumes will not exceed 1,500 ADT based on trip generation factors shown on Std. detail No. 491.01.
3. Certification of construction in compliance with approved design required from Professional Engineer upon completion, including test results on subgrade, stone base, concrete, and asphalt.

	ENGINEERING DEPARTMENT Greenville, North Carolina 27834	<a href="http://www.greenvillenc.gov">www.greenvillenc.gov</a>	Rev. 1 Date 9/1/23 Description APPROVAL Approved L. KIRBY	Sheet # 1 of 2 Scale: not to scale Detail # 410.02
	<b>PRIVATE STREET (CURB &amp; GUTTER)</b>			

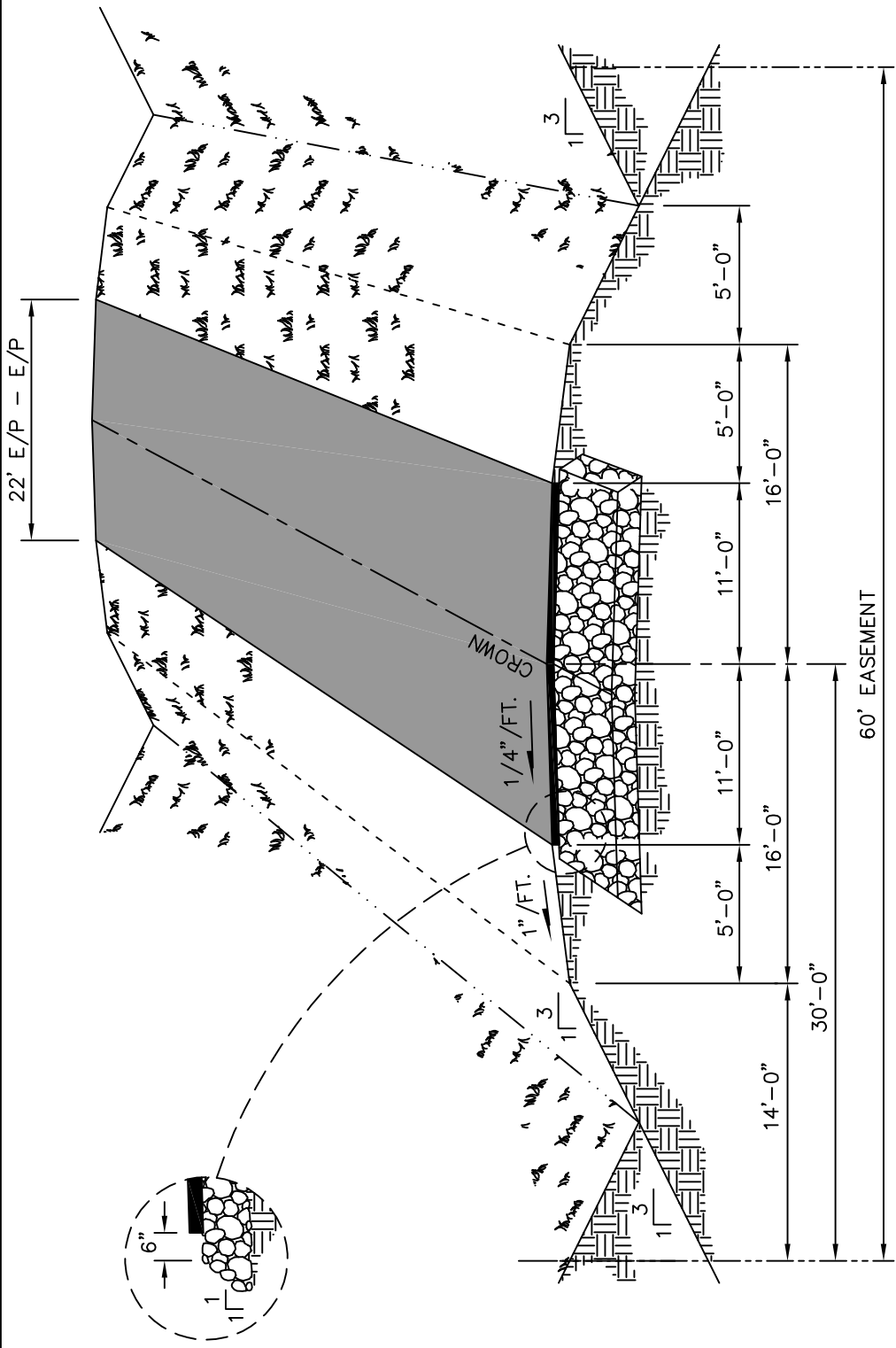

**TYPICAL CROSS SECTION**

"PRIVATE STREET"  
(NON-CURB & GUTTER)

**NOTES:**

1. Pavement design to be according to procedure described in Std. detail No. 490.01.
2. May only be used in cases where projected traffic volumes will not exceed 1,500 ADT based on trip generation factors shown on Std. detail No. 491.01.
3. Certification of construction in compliance with approved design required from Professional Engineer upon completion, including test results on subgrade, stone base, concrete, and asphalt..

	ENGINEERING DEPARTMENT Greenville, North Carolina 27834	<a href="http://www.greenvillenc.gov">www.greenvillenc.gov</a>	Rev. 1 Date 9/1/23 Description APPROVAL	Approved L. KIRBY
	<b>CITY OF GREENVILLE, N.C.</b>			Sheet #: 2 of 2 Scale: not to scale
<b>PRIVATE STREET (NON-CURB &amp; GUTTER)</b>				Detail # <b>410.02</b>

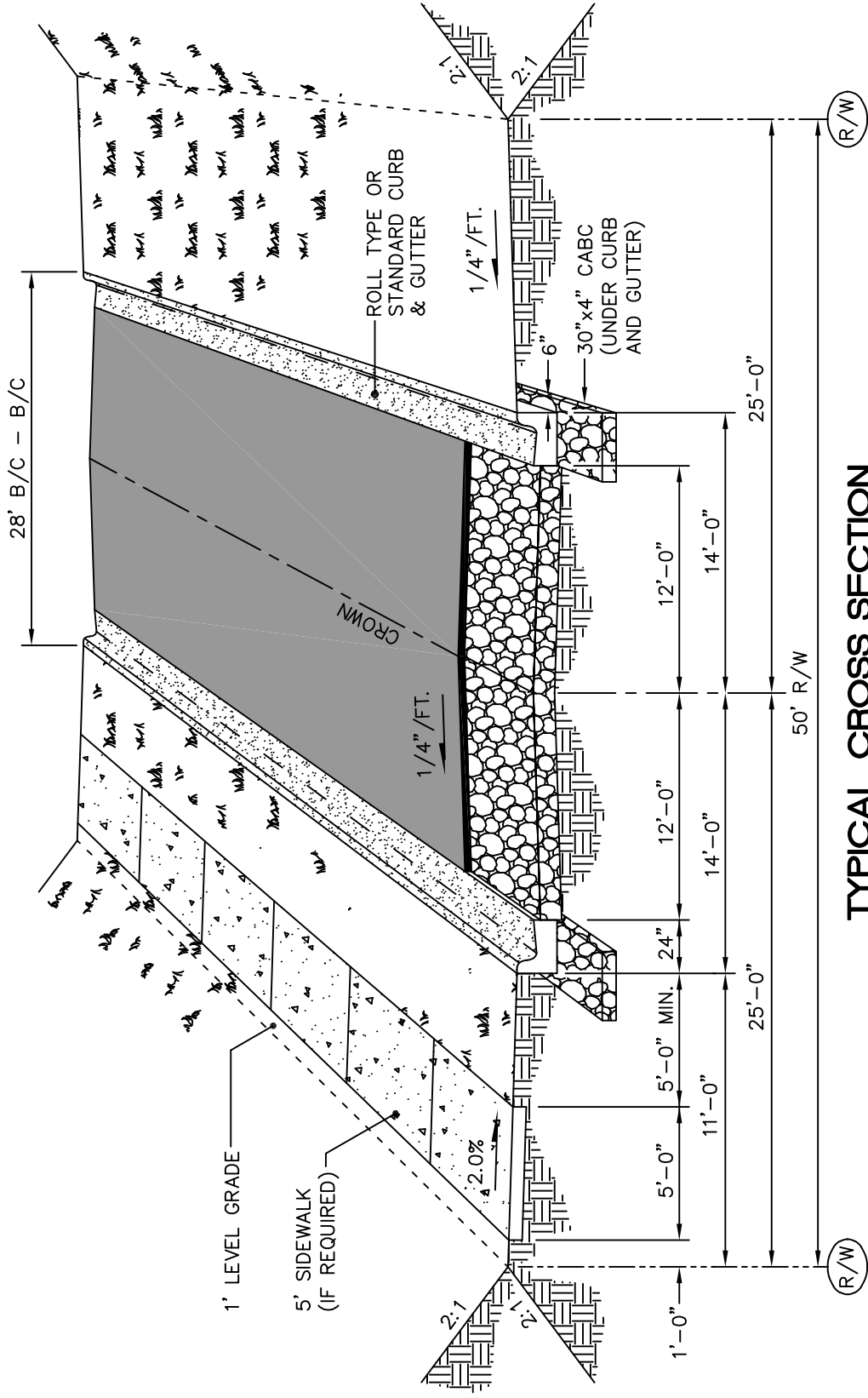

**TYPICAL CROSS SECTION**

"STANDARD RESIDENTIAL STREET"  
(CURB & GUTTER)

**NOTES:**

1. Pavement design to be according to procedure described in Std. detail No. 490.01.
2. May only be used in cases where projected traffic volumes will not exceed 1500 ADT based on trip generation factors shown on Std. detail No. 491.02.
3. Planting strip may be reduced to 2'-0" minimum if roll curb is utilized.



ENGINEERING DEPARTMENT  
Greenville, North Carolina 27834

**CITY OF GREENVILLE, N.C.**

www.greenvillenc.gov

Rev.	Date	Description	Approved
1	9/1/23	APPROVAL	L. KIRBY

Scale: not to scale	Sheet #: 1 of 2	Detail #: 410.03
------------------------	--------------------	---------------------

**STANDARD RESIDENTIAL STREET (CURB & GUTTER)**

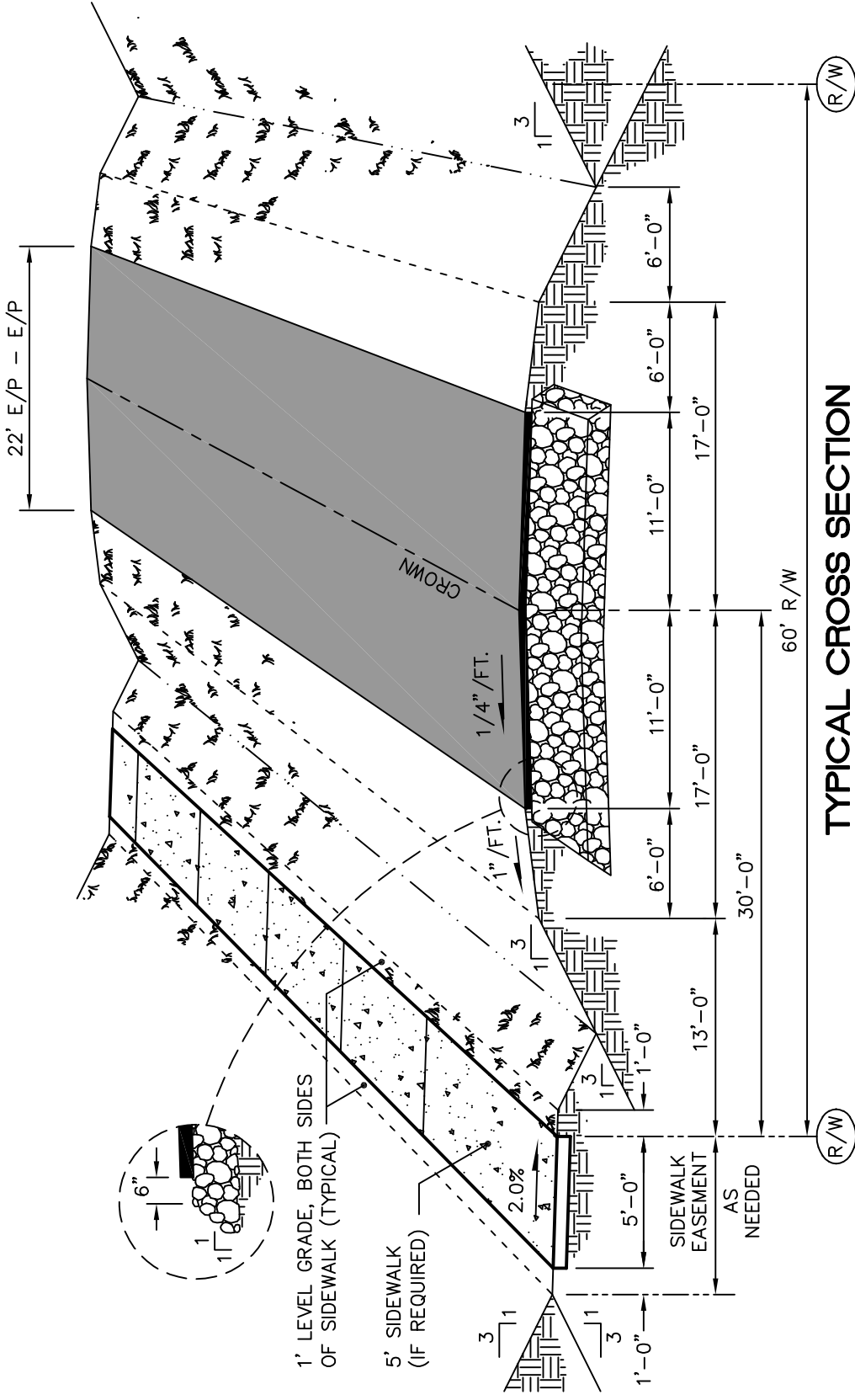

**TYPICAL CROSS SECTION**  
 "STANDARD RESIDENTIAL STREET"  
 (NON-CURB & GUTTER)

**NOTES:**

1. Pavement design to be according to procedure described in Std. detail No. 490.01.
2. May only be used in cases where projected traffic volumes will not exceed 1500 ADT based on trip generation factors shown on Std. detail No 491.02.
3. Tie-in slopes may be shallower, however all drainage must be maintained within R/W..

	ENGINEERING DEPARTMENT Greenville, North Carolina 27834	<a href="http://www.greenvillenc.gov">www.greenvillenc.gov</a>	Rev. 1 Date 9/1/23 Description APPROVAL	Approved L. KIRBY
	<b>CITY OF GREENVILLE, N.C.</b>			Sheet #: 2 of 2 Scale: not to scale

**STANDARD RESIDENTIAL STREET (NON-CURB & GUTTER)**

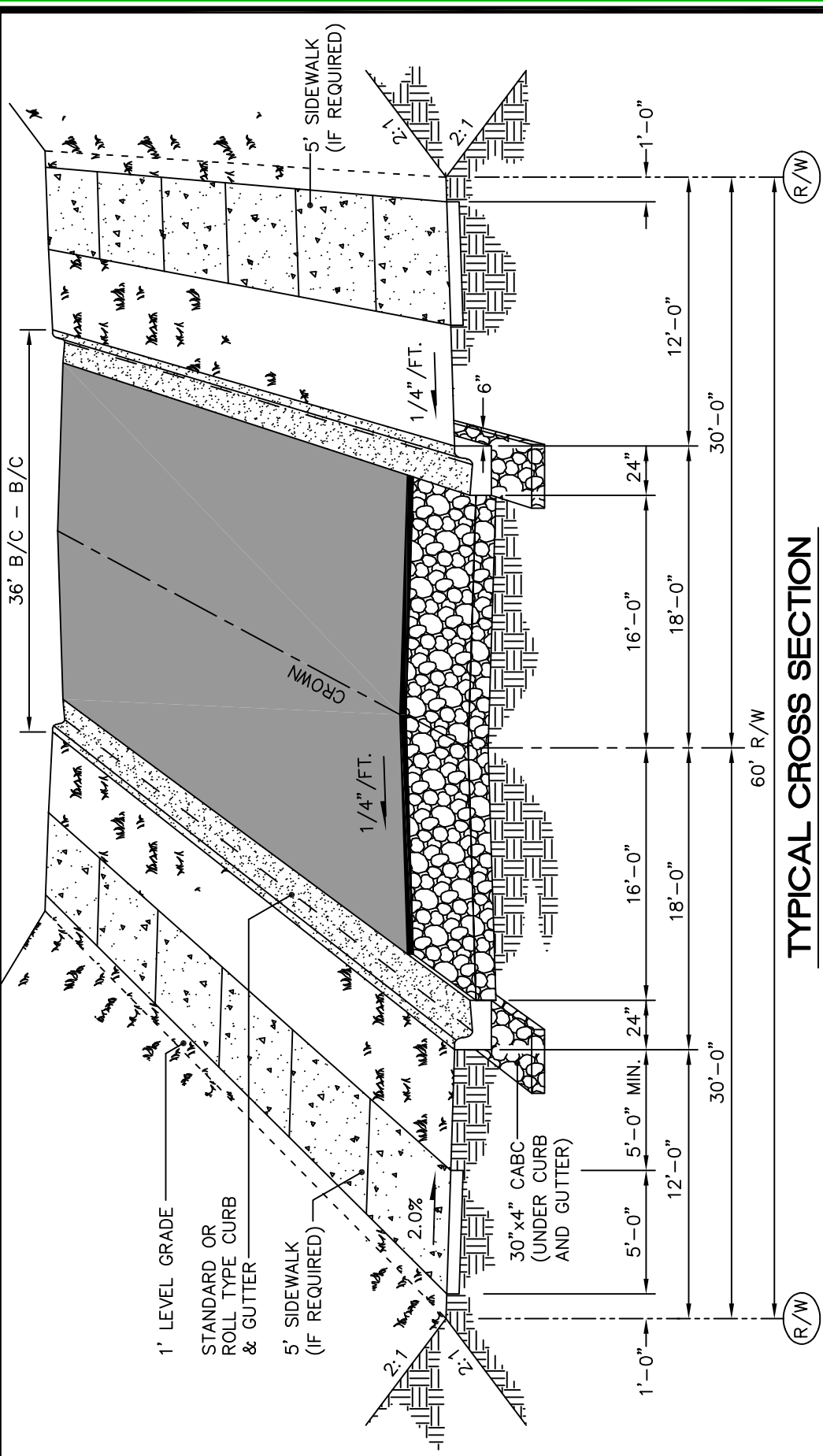

**TYPICAL CROSS SECTION**  
 "COLLECTOR STREET"  
 (CURB & GUTTER)

**NOTES:**

1. Pavement design to be according to procedure described in Std. detail No. 490.01.
2. May only be used in cases where projected traffic volumes will not exceed 3500 ADT based on trip generation factors shown on Std. detail No. 491.02.
3. Planting strip may be reduced to 2'-0" minimum if roll curb is utilized.

	ENGINEERING DEPARTMENT Greenville, North Carolina 27834	<a href="http://www.greenvillenc.gov">www.greenvillenc.gov</a>	Rev. 1 Date 9/1/23 Description APPROVAL	Approved L. KIRBY
	<b>CITY OF GREENVILLE, N.C.</b> <b>COLLECTOR STREET (CURB &amp; GUTTER)</b>			Sheet #: 1 of 2 Scale: not to scale Detail #: 410.04



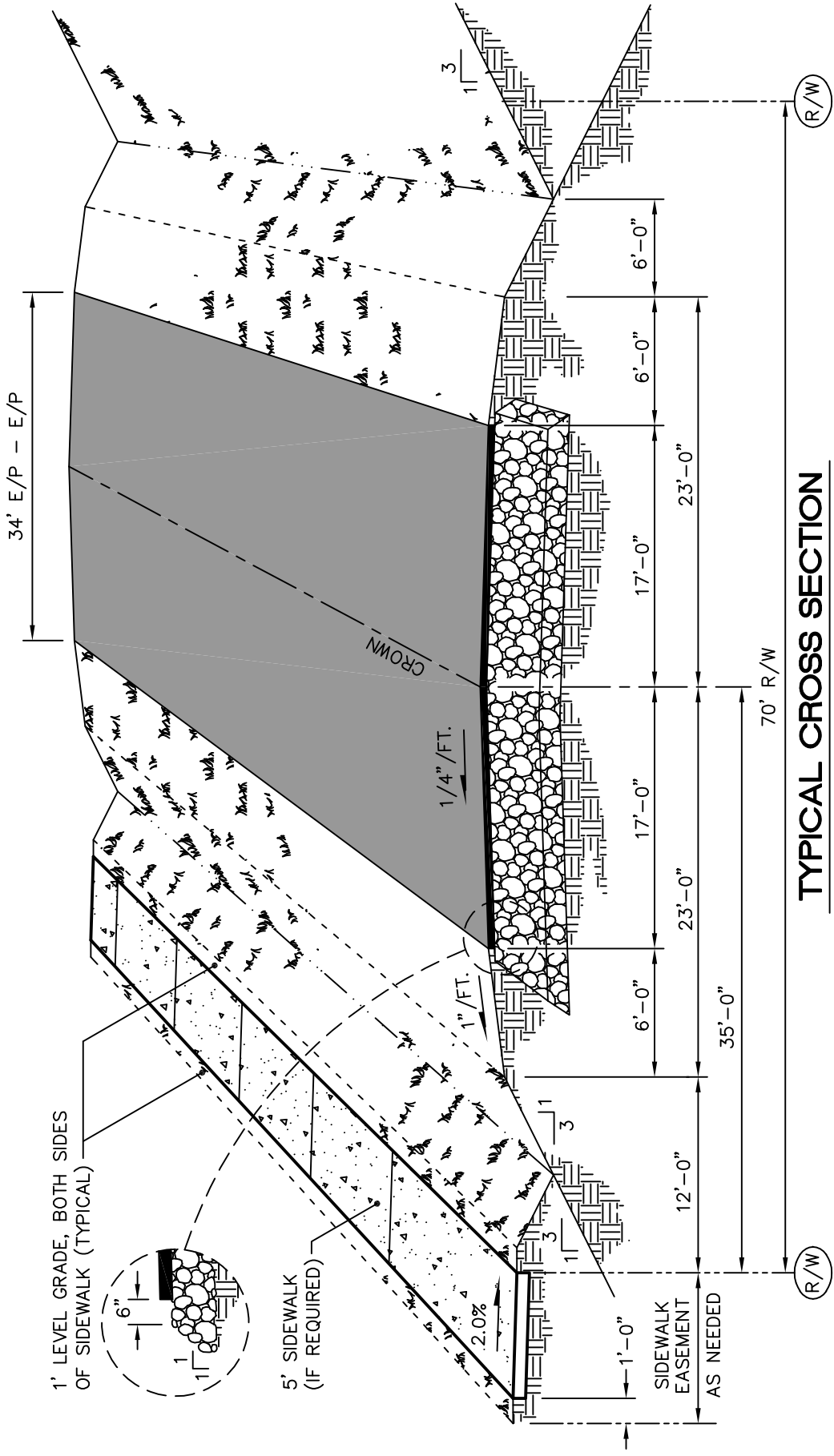

**NOTES:**

1. Pavement design to be according to procedure described in Std. detail No. 490.01.
2. May only be used in cases where projected traffic volumes will not exceed 3500 ADT based on trip generation factors shown on Std. detail No. 491.02.
3. Tie-in slopes may be shallower, however all drainage must be maintained within R/W.

	ENGINEERING DEPARTMENT Greenville, North Carolina 27834	<a href="http://www.greenvillenc.gov">www.greenvillenc.gov</a>	Rev. 1 Date 9/1/23 Description APPROVAL Approved L. KIRBY	Detail # <b>410.04</b>
	<b>COLLECTOR STREET (NON-CURB &amp; GUTTER)</b>		Scale: not to scale Sheet #: 2 of 2	

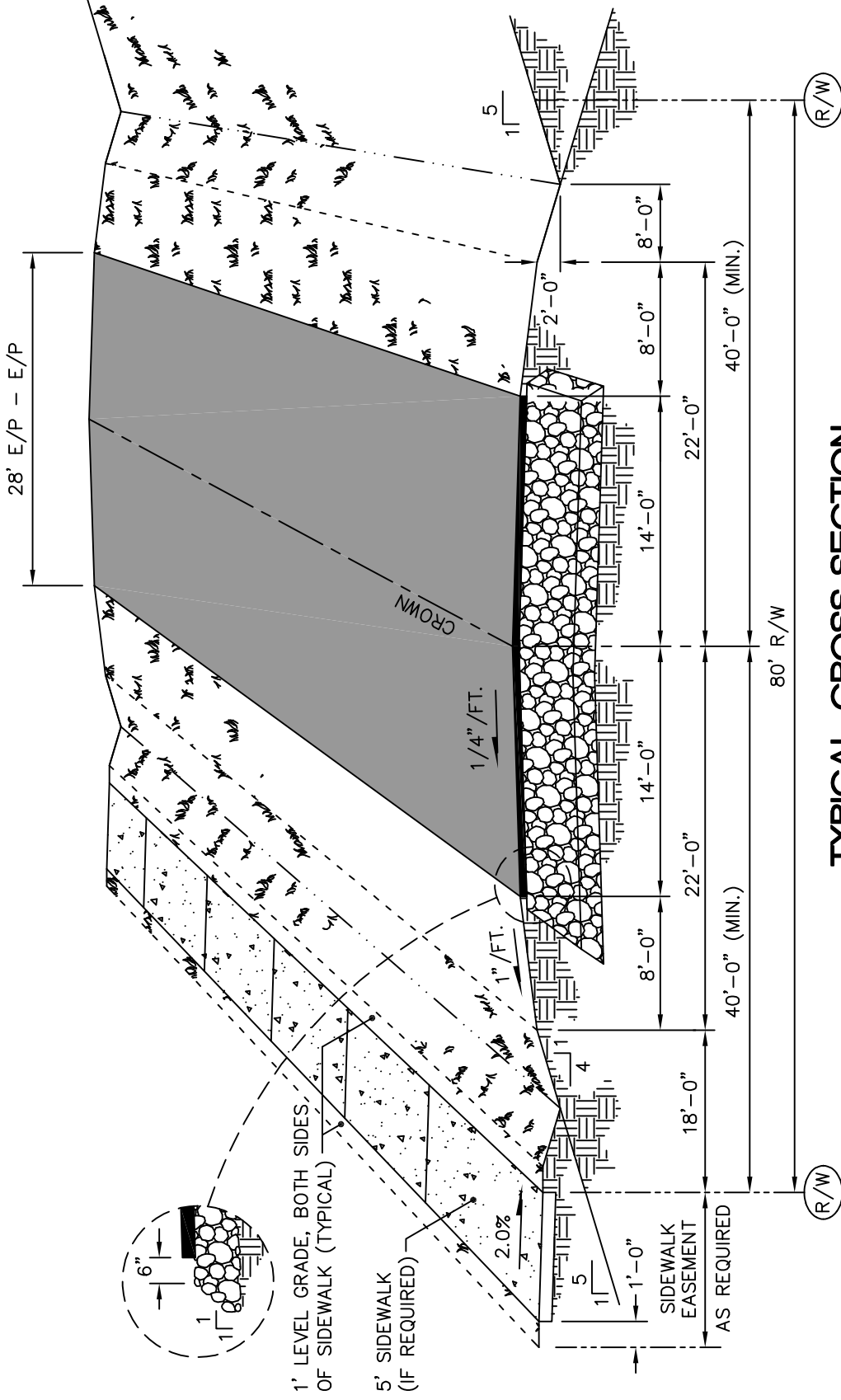

**TYPICAL CROSS SECTION**  
 "PLANNED INDUSTRIAL STREET"  
 (NON-CURB & GUTTER)

**NOTES:**

- Pavement design to be according to procedure described in Std. detail no. 490.01.



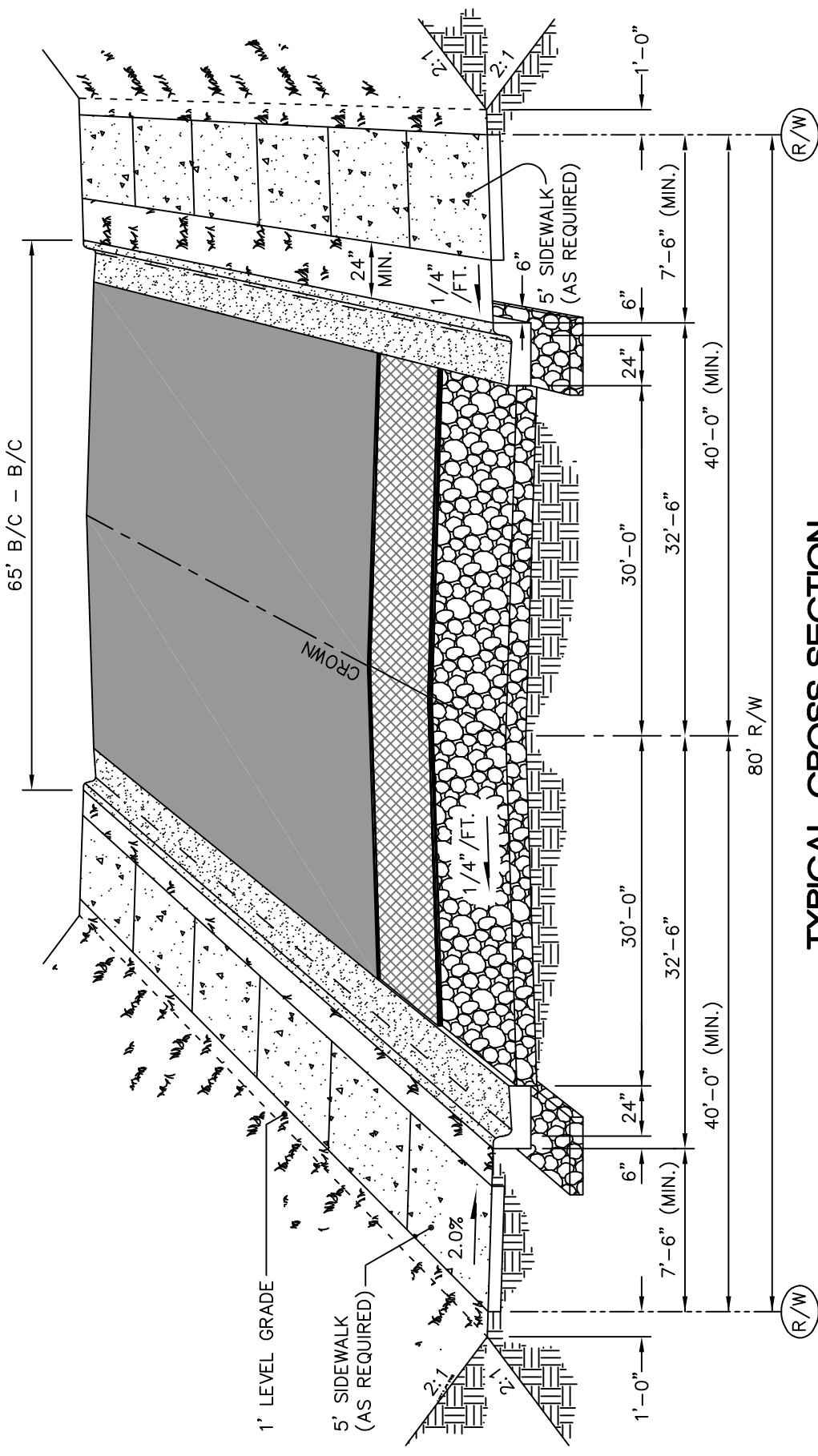

**TYPICAL CROSS SECTION**

"MINOR THOROUGHFARE"

**NOTES:**

1. Pavement design to be according to procedure described in Std. detail No. 490.01.
2. Pavement markings to be determined as part of the review process & must comply with MUTCD.

	ENGINEERING DEPARTMENT Greenville, North Carolina 27834	<a href="http://www.greenvillenc.gov">www.greenvillenc.gov</a>	Rev. 1 Date 9/1/23 Description APPROVAL	Approved L. KIRBY
	<b>CITY OF GREENVILLE, N.C.</b>			Detail # 410.06
<b>STANDARD TYPICAL SECTION - MINOR THOROUGHFARE</b>				Sheet #: 1 of 1 Scale: not to scale

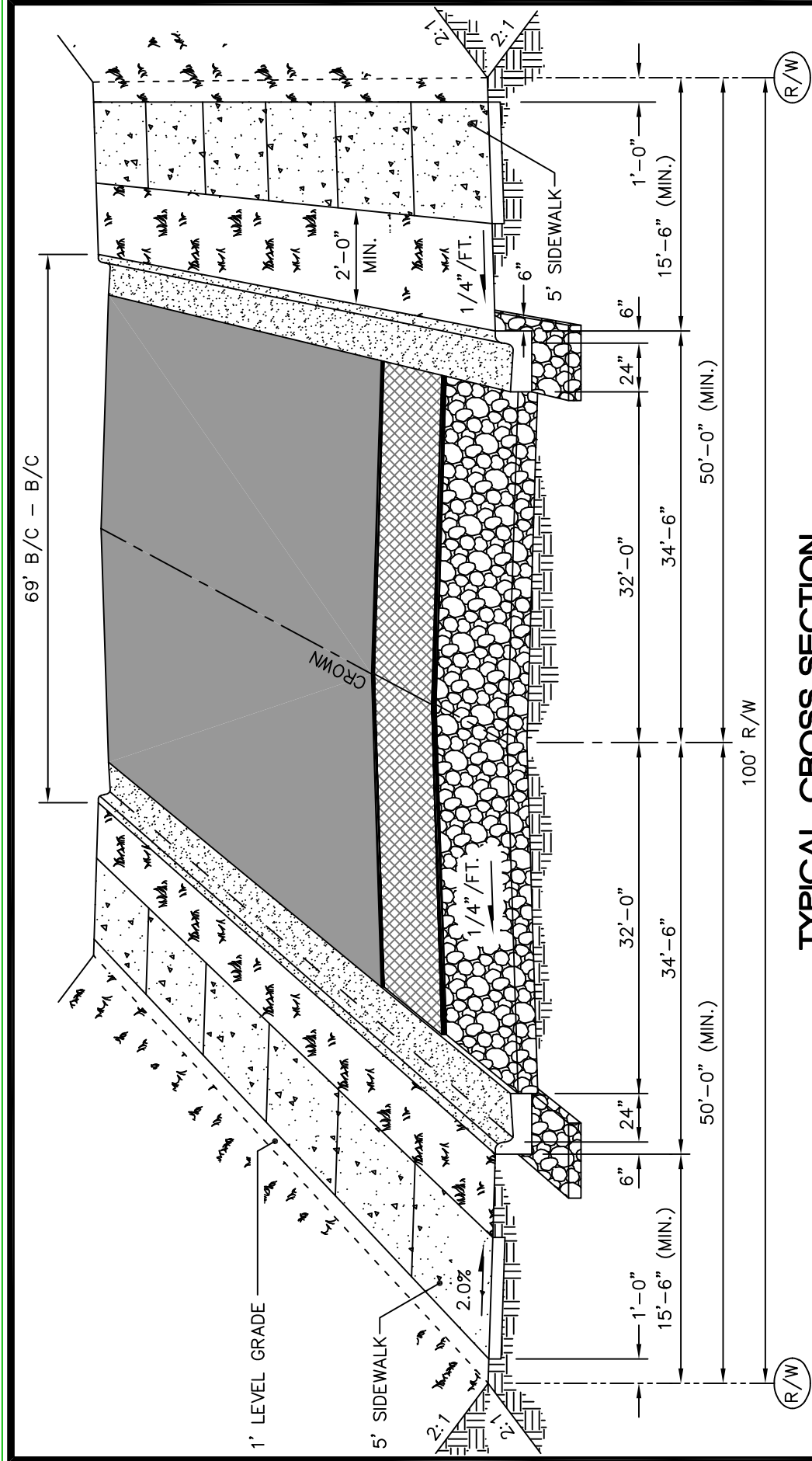

**TYPICAL CROSS SECTION**

"MAJOR THOROUGHFARE"

**NOTES:**

1. Pavement design to be according to procedure described in std. detail No. 490.01.
2. Pavement markings to be determined as part of the review process & must comply with MUTCD.

	ENGINEERING DEPARTMENT Greenville, North Carolina 27834	<a href="http://www.greenvillenc.gov">www.greenvillenc.gov</a>	Rev. 1 Date 9/1/23 Description APPROVAL	Approved L. KIRBY
	<b>STANDARD TYPICAL SECTION - MAJOR THOROUGHFARE</b>			Sheet #: 1 of 1 Scale: not to scale Detail #: <b>410.07</b>

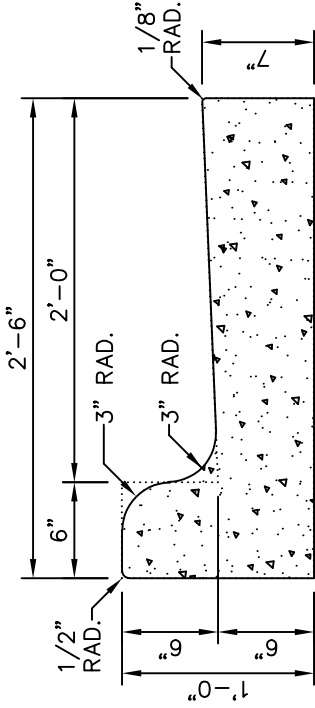

### 2'-6" CURB AND GUTTER

30" CURB AND GUTTER SHALL BE PLACED IN NCDOT R/W.

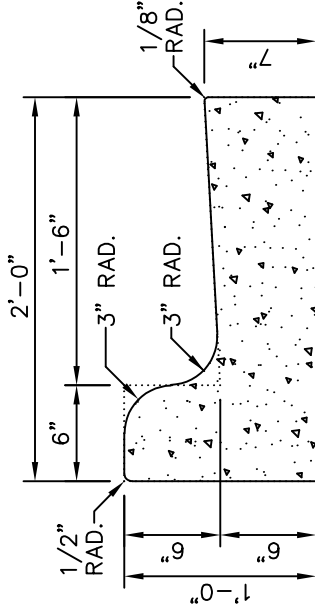

### 2'-0" CURB AND GUTTER

24" CURB AND GUTTER SHALL BE PLACED IN RESIDENTIAL DEVELOPMENTS OR AS PROVIDED IN THE MSDD.

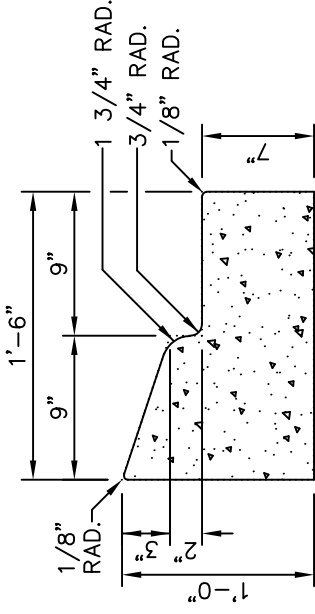

### 1'-6" CURB AND GUTTER

(TO BE USED IN MEDIANS ONLY)

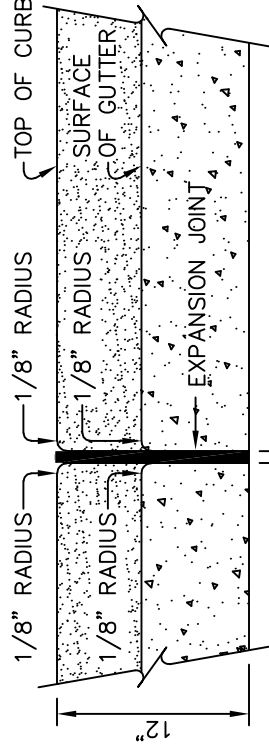

### TRANSVERSE EXPANSION JOINT IN CURB AND GUTTER

#### NOTES:

1. Contraction joints shall be placed at 10' intervals, except that 15' spacing may be used when satisfactory support for the face form can be obtained without the use of templates at 10' intervals. Joint spacing may be altered by the engineer to prevent uncontrolled cracking.
2. Contraction joints may be installed by the use of templates or formed by other approved methods. Where such joints are not formed by templates, a minimum depth of 1 1/2" shall be obtained.
3. Minimum section length of curb & gutter shall be 5 feet.
4. Expansion joints shall be spaced at 90' intervals, and adjacent to all rigid objects.
5. Flexible forms are to be used when radius is less than 200'.
6. Installation shall be in accordance with NCDOT Standards and Specifications. Joint sealer not required.



ENGINEERING DEPARTMENT  
Greenville, North Carolina 27834

**CITY OF GREENVILLE, N.C.**

Rev.	Date	Description	Approved
1	9/1/23	APPROVAL	L. KIRBY

### STANDARD CURB & GUTTER

Scale:	Sheet #:	Detail #:
not to scale	1 of 1	411.01

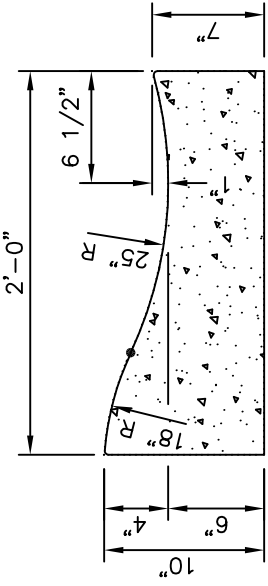

**ROLL TYPE CURB AND GUTTER**

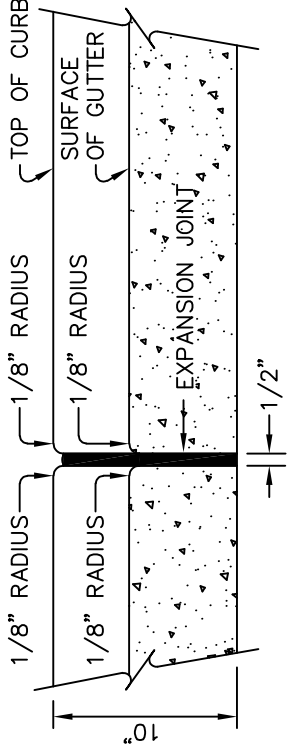

**TRANSVERSE EXPANSION  
JOINT IN CURB AND GUTTER**

**NOTES:**

1. Contraction joints shall be placed at 10' intervals, except that 15' spacing may be used when a machine is used or when satisfactory support for the face form can be obtained without the use of templates at 10' intervals. Joint spacing may be altered by the engineer to prevent uncontrolled cracking.
2. Contraction joints may be installed by the use of templates or formed by other approved methods. Where such joints are not formed by templates, a minimum depth of 1 1/2" shall be obtained.
3. Expansion joints shall be spaced at 90' intervals, and adjacent to all rigid objects.
4. Flexible forms are to be used when radius is less than 200'.
5. Installation shall be in accordance with NCDOT Standards and Specifications. Joint sealer not required.



ENGINEERING DEPARTMENT  
Greenville, North Carolina 27834

**CITY OF GREENVILLE, N.C.**

www.greenvillenc.gov

**STANDARD ROLL-TYPE CURB AND GUTTER**

Rev.	Date	Description	Approved	Detail #
1	9/1/23	APPROVAL	L. KIRBY	411.02
Scale: not to scale				Sheet #: 1 of 1

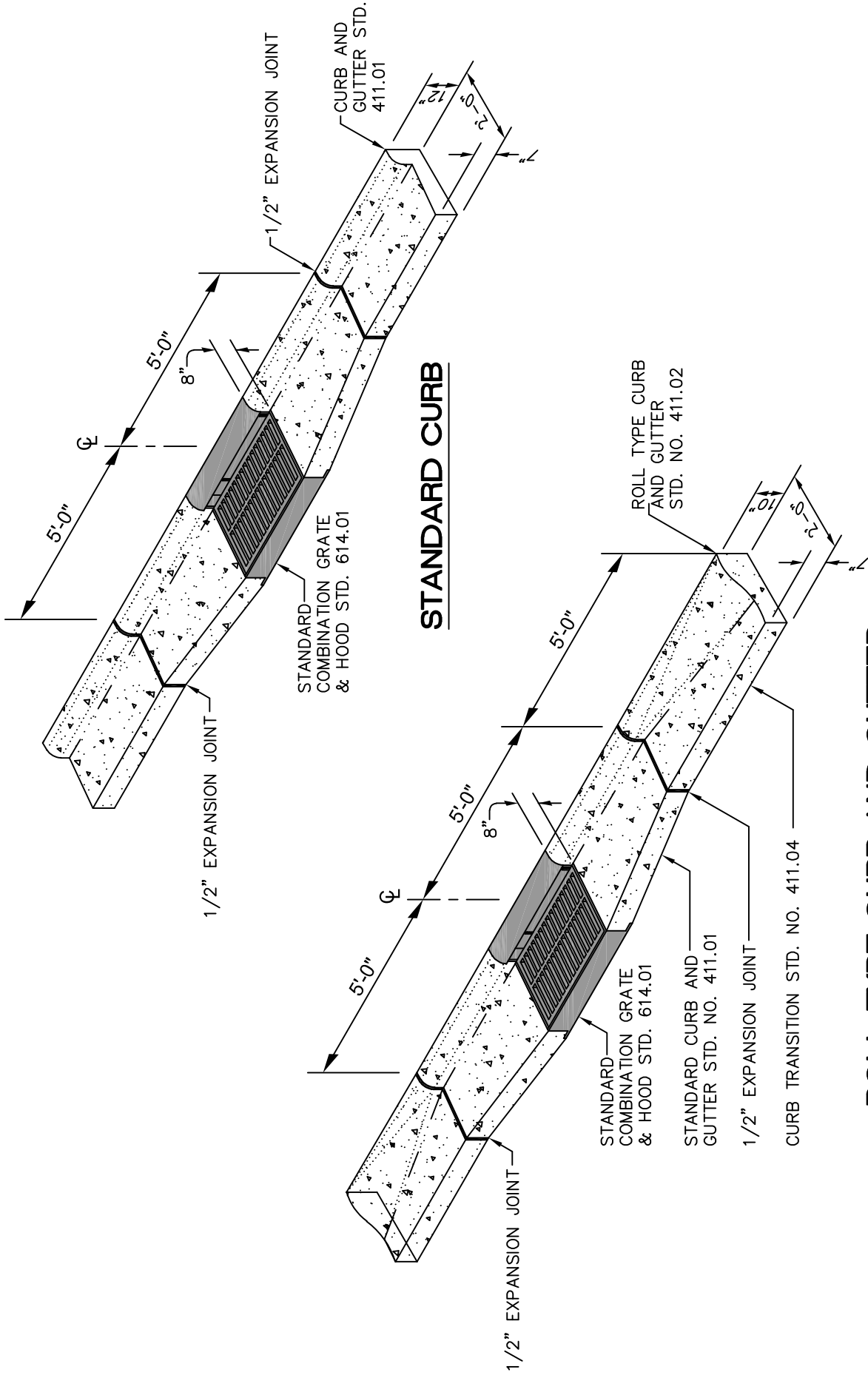

**STANDARD CURB**

**ROLL TYPE CURB AND GUTTER**

Rev.	Date	Description	Approved
1	9/1/23	APPROVAL	L. KIRBY

Scale: not to scale  
 Sheet #: 1 of 1  
 Detail #: 411.03

ENGINEERING DEPARTMENT  
 Greenville, North Carolina 27834  
[www.greenvillenc.gov](http://www.greenvillenc.gov)  
**CITY OF GREENVILLE, N.C.**  
**STANDARD CATCH BASIN FRAME 2'-0" IN CURB AND GUTTER**



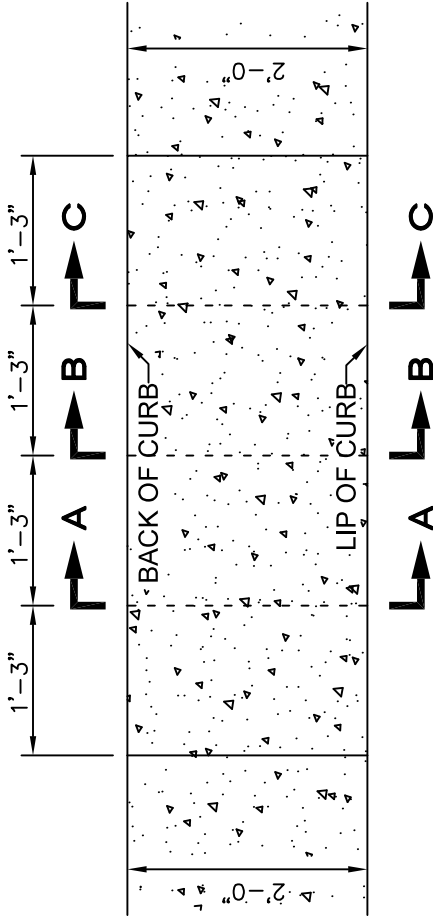

STANDARD CURB  
AND GUTTER STD.  
NO. 411.01

BEGIN 2'-0" ROLL - TYPE CURB  
AND GUTTER STD. NO. 411.02

PLAN VIEW

FRONT ELEVATION

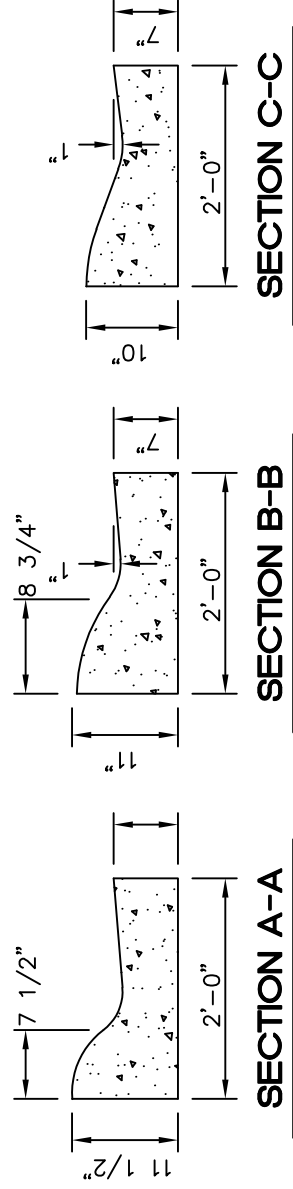

NOTES:

1. Transition is NOT to be located within the curb radius.



ENGINEERING DEPARTMENT  
Greenville, North Carolina 27834

**CITY OF GREENVILLE, N.C.**

www.greenvillenc.gov

Rev.	Date	Description	Approved
1	9/1/23	APPROVAL	L. KIRBY

**CURB TRANSITION - 2'-0" C&G TO 2'-0" ROLL TYPE C&G**

Scale:	Sheet #:	Detail #:
not to scale	1 of 1	411.04



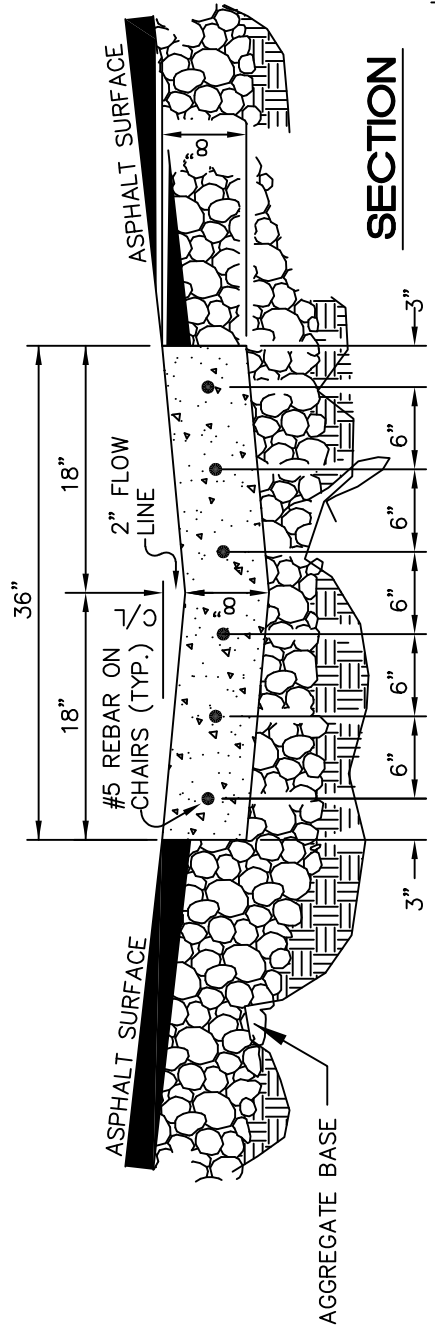

**SECTION**

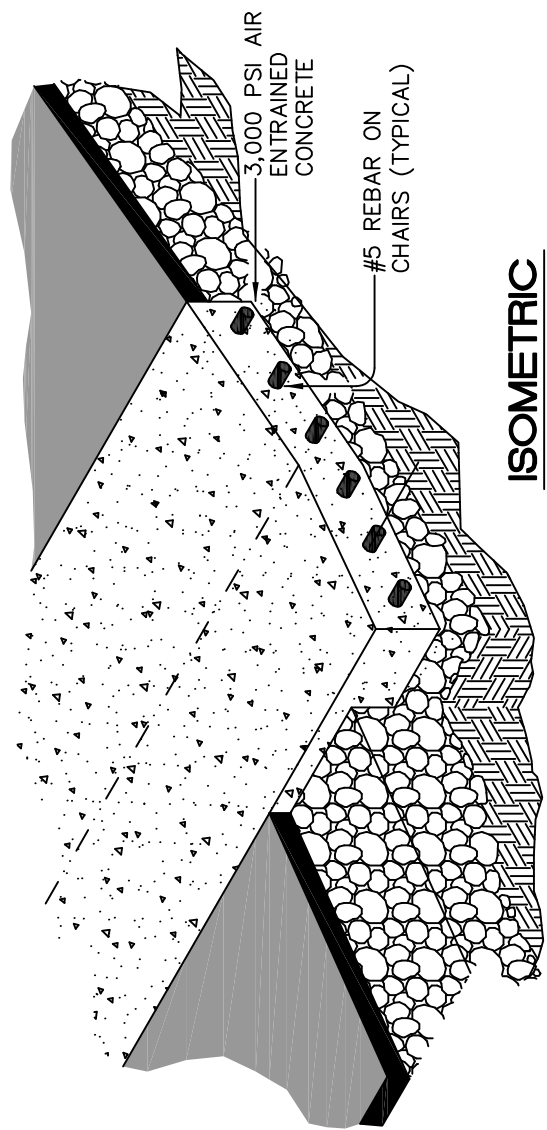

**ISOMETRIC**

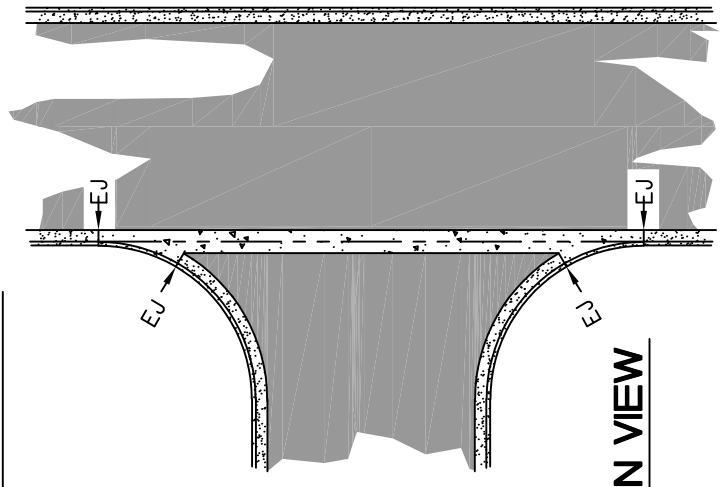

**PLAN VIEW**

**NOTES:**

1. For use with 24" standard curb and gutter.
2. Installation shall be in accordance with NCDOT Standards and Specifications. Joint sealer not required.
3. Lap rebar a minimum of 12" at joints.
4. Contact the Engineering Department Land Development Division a minimum of 24 hours in advance for a pre-pour inspection.

	ENGINEERING DEPARTMENT Greenville, North Carolina 27834	<b>CITY OF GREENVILLE, N.C.</b> <a href="http://www.greenvillenc.gov">www.greenvillenc.gov</a>		Rev. 1 Date 9/1/23 Description APPROVAL Approved L. KIRBY	Sheet # 1 of 2 Scale: not to scale Detail # <b>411.05</b>
	<b>36" CONCRETE VALLEY GUTTER</b>				

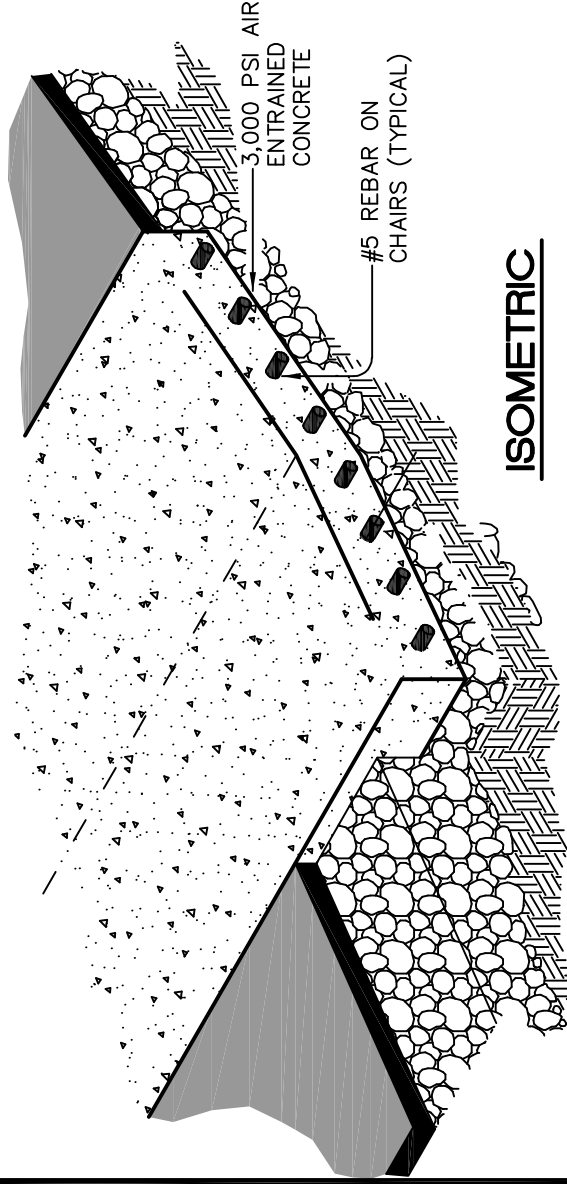
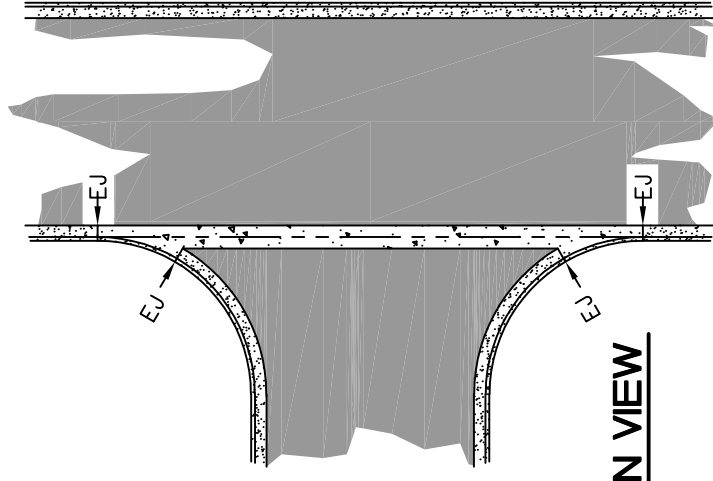
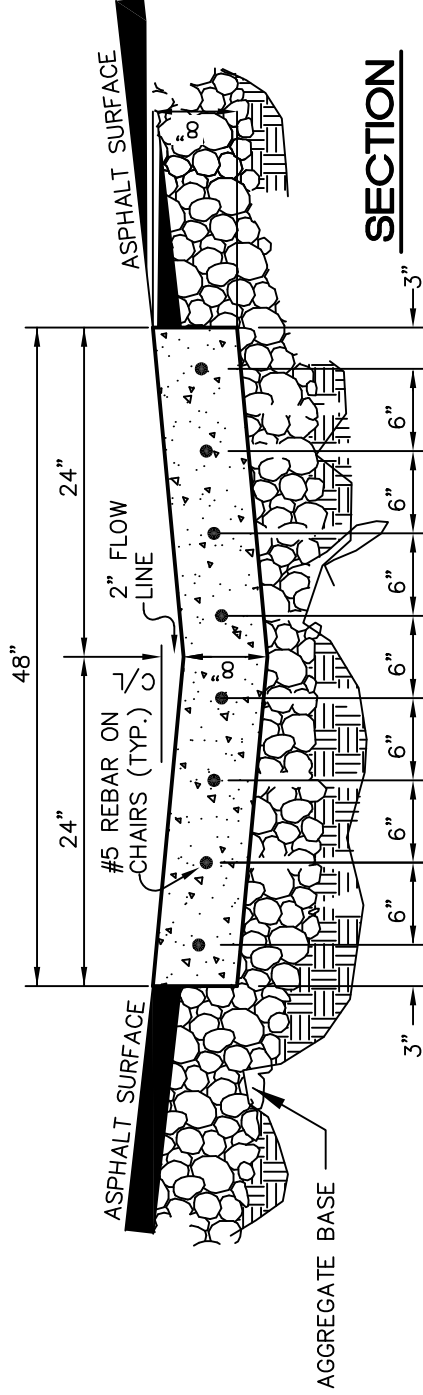

**NOTES:**

1. For use with 30" standard curb and gutter.
2. Installation shall be in accordance with NCDOT Standards and Specifications. Joint sealer not required.
3. Lap rebar a minimum of 12" at joints.
4. Contact the Engineering Department Land Development Division a minimum of 24 hours in advance for a pre-pour inspection.

	ENGINEERING DEPARTMENT Greenville, North Carolina 27834	<a href="http://www.greenvillenc.gov">www.greenvillenc.gov</a>	Rev. 1 Date 9/1/23 Description APPROVAL	Approved L. KIRBY
	<b>CITY OF GREENVILLE, N.C.</b>		<b>48" CONCRETE VALLEY GUTTER</b>	
Scale: not to scale			Sheet #: 2 of 2	Detail # 411.05

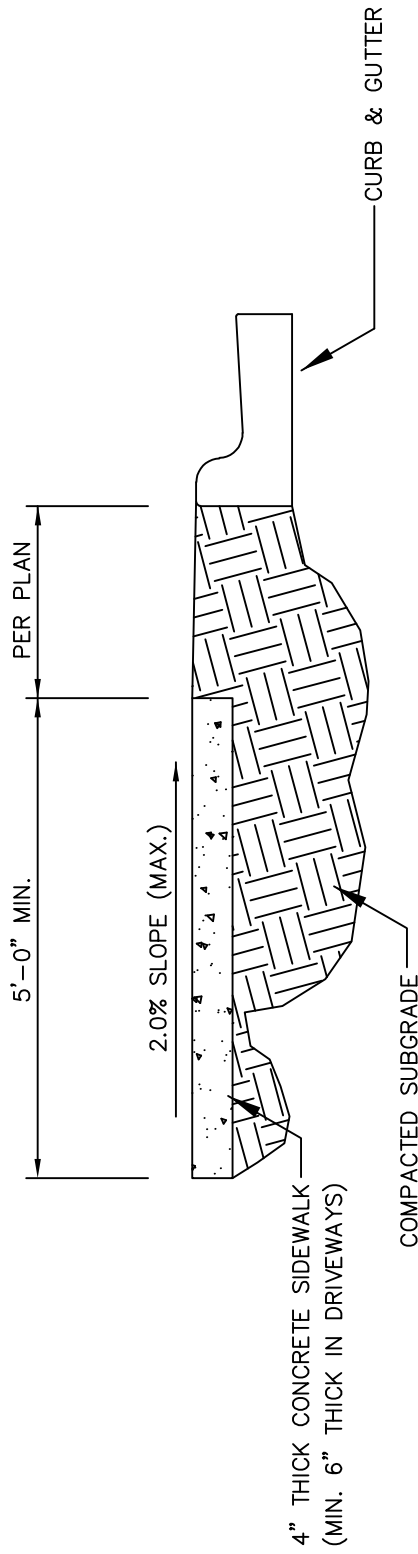

**NOTES:**

1. Concrete shall be minimum Class "B" (2,500 PSI).
2. All sidewalks shall be installed in accordance with ADA regulations.
3. Contraction joints shall be placed at 5' intervals.
4. Minimum section length of sidewalk shall be 5 feet.
5. Expansion joints shall be spaced at 90' intervals, and adjacent to all rigid objects.
6. Installation shall be in accordance with NCDOT Standards and Specifications. Joint sealer not required.
7. Within the right of way the maximum running slope shall not exceed the general grade established for the adjacent street. Outside right of way the maximum running slope shall be 5.0%.



ENGINEERING DEPARTMENT  
Greenville, North Carolina 27834

**CITY OF GREENVILLE, N.C.**

www.greenvillenc.gov

Rev.	Date	Description	Approved
1	9/1/23	APPROVAL	L. KIRBY

Scale: not to scale	Sheet #: 1 of 1	Detail #: <b>411.06</b>
------------------------	--------------------	----------------------------

**CONCRETE SIDEWALK**

R	48.5' TO BACK OF CURB (MIN.)
R <sup>1</sup>	0' TO 15' TO BACK OF CURB (MAX.)
D	VARIABLE
CUL-DE-SAC MAY BE OFFSET FROM CENTERLINE OF STREET.	

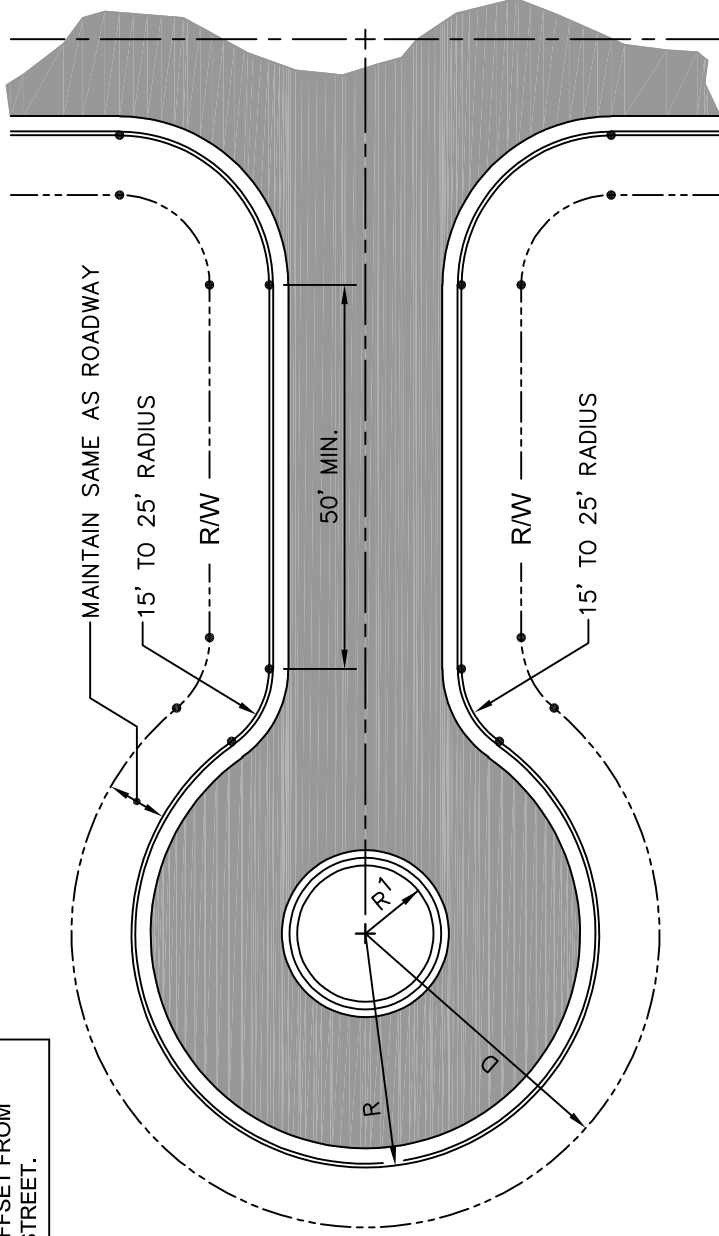

**NOTES:**

1. Interior island is NOT required.
2. If installed, center island to be R/W maintained by HOA.
3. Center islands larger than specified in table allowed with City Engineer approval. Outer radius (R) shall increase proportional to increase of center island radius (R<sup>1</sup>).
4. No parking in cul-de-sac.
5. Mountable (median) curb on island.
6. Maximum height of vegetation (at maturity) to be installed in center island is 30 inches. Larger vegetation within island to be reviewed & approved by City Engineer. Encroachment agreement required for all non-vegetative improvements. No vegetation or other improvements shall be installed within 5' of back of curb in center island.
7. All dead end access roads in excess of 150 feet shall be provided with a proper fire apparatus turnaround as approved in Appendix D of the latest edition of the North Carolina Fire Code.



ENGINEERING DEPARTMENT  
Greenville, North Carolina 27834

**CITY OF GREENVILLE, N.C.**

www.greenvillenc.gov

Rev.	Date	Description	Approved
1	9/1/23	APPROVAL	L. KIRBY

Scale: not to scale	Sheet #: 1 of 1	Detail #: <b>412.01</b>
------------------------	--------------------	----------------------------

**STANDARD CUL-DE-SAC**

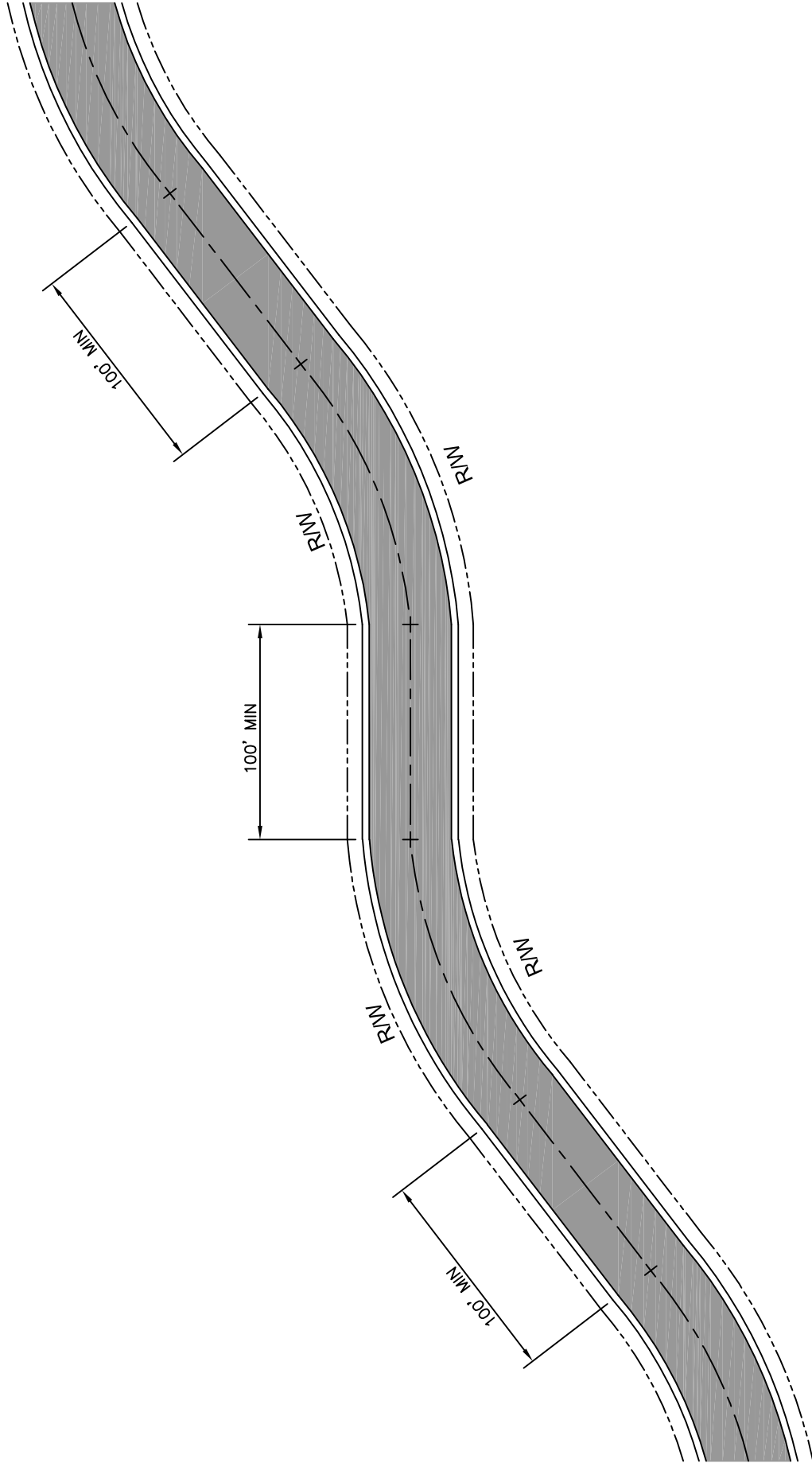

**NOTES:**

1. A minimum of 100 ft. tangent distance is required between reverse curves on residential streets, collector streets, and all thoroughfares.



ENGINEERING DEPARTMENT  
Greenville, North Carolina 27834

**CITY OF GREENVILLE, N.C.**

[www.greenvillenc.gov](http://www.greenvillenc.gov)

Rev.	Date	Description	Approved
1	9/1/23	APPROVAL	L. KIRBY

Scale: not to scale	Sheet #: 1 of 1	Detail #: <b>412.02</b>
------------------------	--------------------	----------------------------

**TANGENT DISTANCES AT REVERSE CURVES**

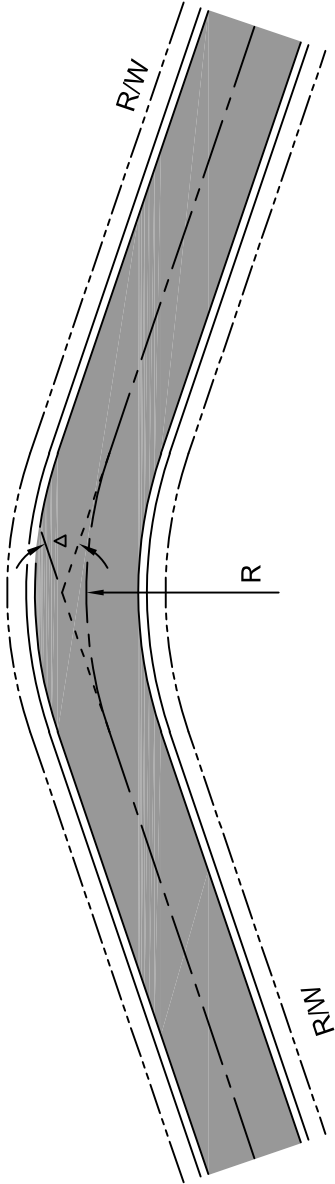

**NOTES:**

- When connecting street centerlines deflect from each other at any one point by more than five degrees, ( $\Delta > 5^\circ$ ), they shall be connected by a curve with a radius of not less than 100 feet ( $R \geq 100'$ ) for residential streets. For collector streets and thoroughfares, the radius should be sufficient to ensure a sight distance adequate for visibility and safety, considering the character of the street and the types and the speed of traffic anticipated, but in no case shall such radius be less than 200 feet ( $R \geq 200'$ ).



ENGINEERING DEPARTMENT  
Greenville, North Carolina 27834

**CITY OF GREENVILLE, N.C.**

www.greenvillenc.gov

Rev.	Date	Description	Approved
1	9/1/23	APPROVAL	L. KIRBY

**CURVE RADIUS AT DEFLECTING STREET LINES**

Scale:	Sheet #:	Detail #:
not to scale	1 of 1	412.03

$K = L/A$   
 $L =$  length of vertical curve  
 $A =$  algebraic difference in grade

## VERTICAL CURVE TABLE

DESIGN SPEED (mph)	MIN. STOPPING SIGHT DISTANCE (ft)	K (crest) (deg)	K (sag) (deg)	K (stop) (deg)
25	155	26	26	12
30	200	37	37	19
35	250	49	49	29
40	305	64	64	44
45	360	79	79	61
50	425	96	96	84
55	495	115	115	114

**NOTES:**

- Design speed is equal to the posted speed limit plus 10 MPH.
- K(stop) values may be used within 50' of centerline of intersection on stop controlled approaches.



ENGINEERING DEPARTMENT  
Greenville, North Carolina 27834

CITY OF GREENVILLE, N.C.

www.greenvillenc.gov

Rev.	Date	Description	Approved
1	9/1/23	APPROVAL	L. KIRBY

## VERTICAL CURVE DESIGN TABLE

Scale: not to scale	Sheet #: 1 of 1	Detail #: <b>412.04</b>
------------------------	--------------------	----------------------------

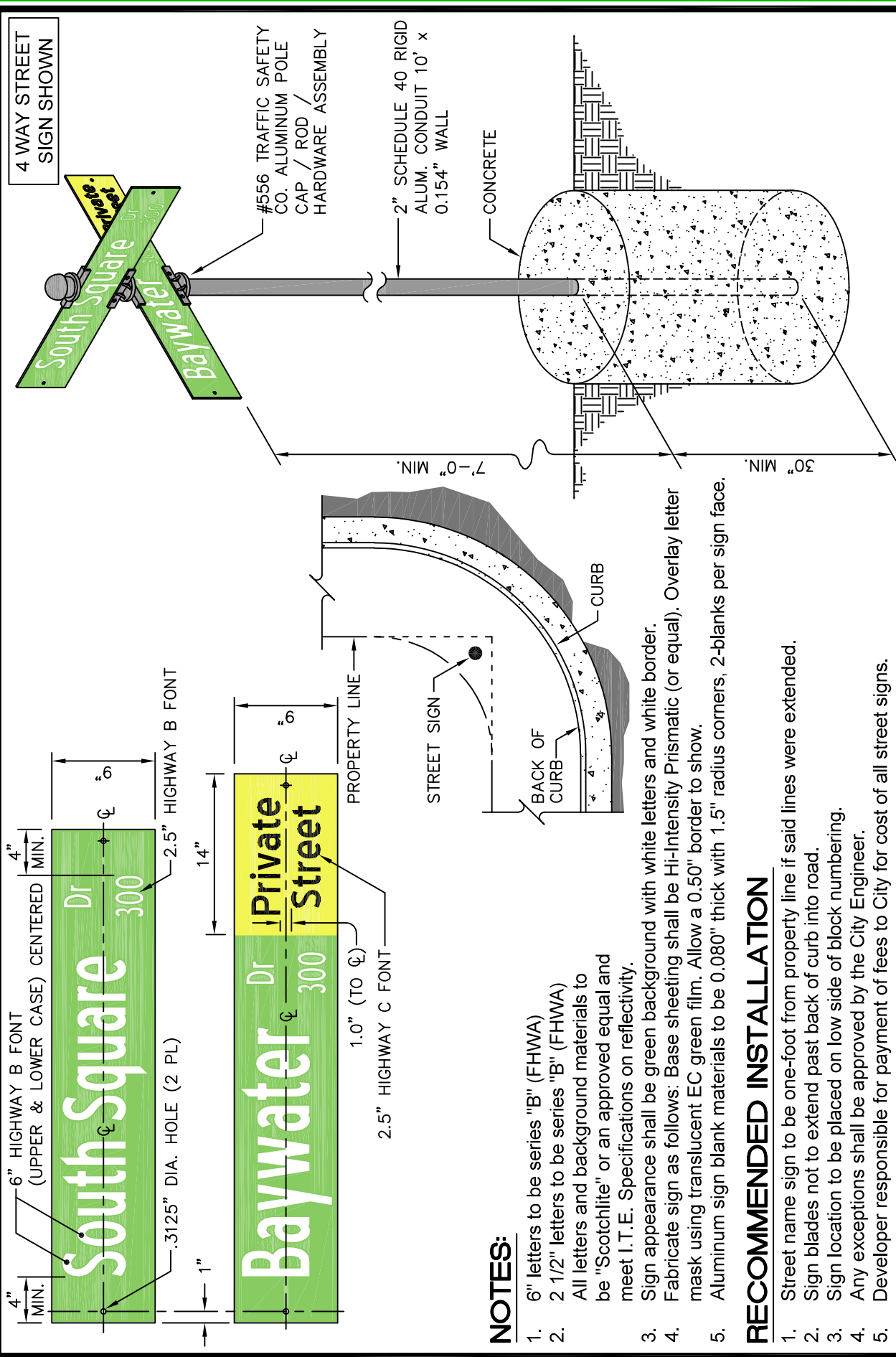

4 WAY STREET SIGN SHOWN

#556 TRAFFIC SAFETY CO. ALUMINUM POLE CAP / ROD / HARDWARE ASSEMBLY

2" SCHEDULE 40 RIGID ALUM. CONDUIT 10' x 0.154" WALL

CONCRETE

7'-0" MIN.

3'-0" MIN.

**NOTES:**

1. 6" letters to be series "B" (FHWA)
2. 2 1/2" letters to be series "B" (FHWA)
3. All letters and background materials to be "Scotchlite" or an approved equal and meet I.T.E. Specifications on reflectivity.
4. Sign appearance shall be green background with white letters and white border.
5. Fabricate sign as follows: Base sheeting shall be Hi-Intensity Prismatic (or equal). Overlay letter mask using translucent EC green film. Allow a 0.50" border to show.
6. Aluminum sign blank materials to be 0.080" thick with 1.5" radius corners, 2-blanks per sign face.

**RECOMMENDED INSTALLATION**

1. Street name sign to be one-foot from property line if said lines were extended.
2. Sign blades not to extend past back of curb into road.
3. Sign location to be placed on low side of block numbering.
4. Any exceptions shall be approved by the City Engineer.
5. Developer responsible for payment of fees to City for cost of all street signs.

	ENGINEERING DEPARTMENT Greenville, North Carolina 27834	<a href="http://www.greenvillenc.gov">www.greenvillenc.gov</a>	Approved L. KIRBY
	<b>CITY OF GREENVILLE, N.C.</b>		
<b>STREET NAME SIGNS - 9" SIGN HEIGHT</b>			Detail # <b>414.01</b>
Scale: not to scale			Sheet #: 1 of 1
Rev. 1 Date 9/1/23 Description APPROVAL			Approved L. KIRBY



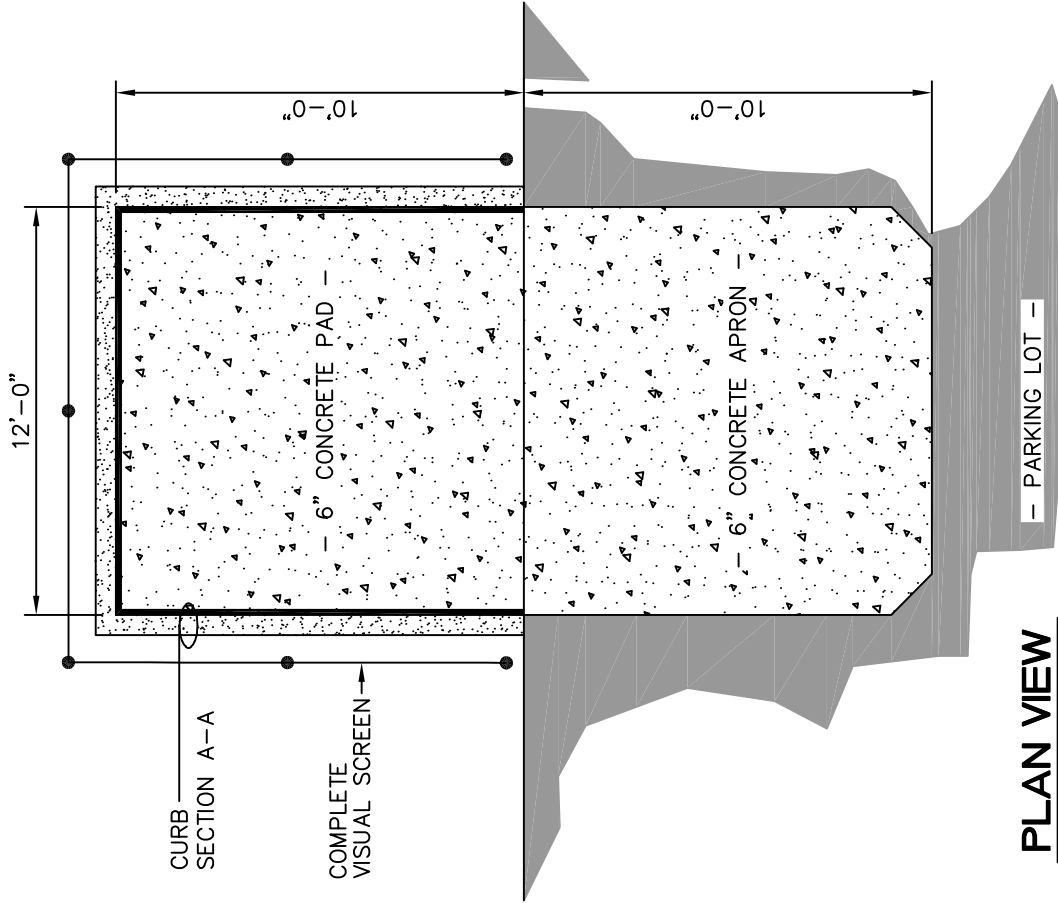
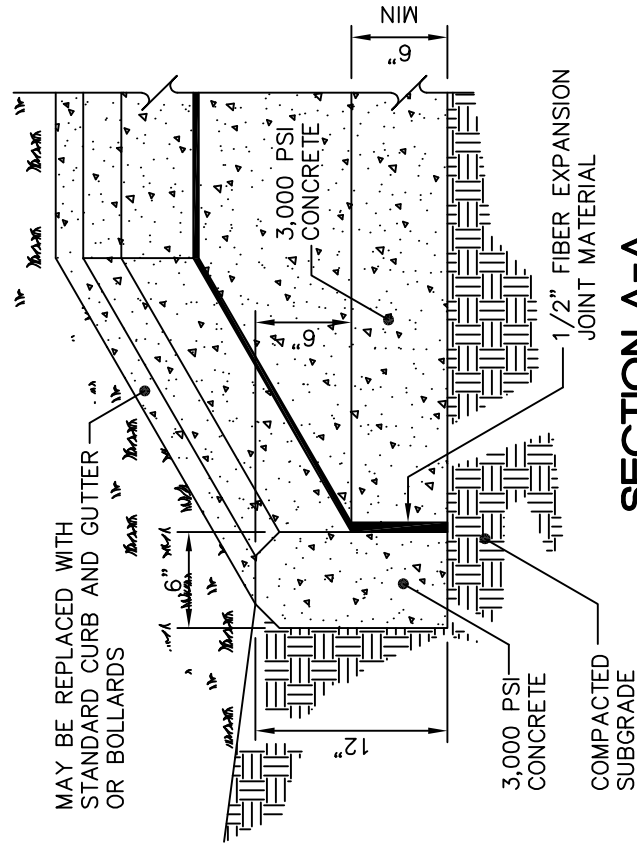

Rev.	Date	Description	Approved
1	9/1/23	APPROVAL	L. KIRBY

www.greenvillenc.gov

**CITY OF GREENVILLE, N.C.**

ENGINEERING DEPARTMENT  
Greenville, North Carolina 27834



**DUMPSTER PAD DETAIL**

Scale:	Sheet #:	Detail #:
not to scale	1 of 1	415.01

**CONTAINER REQUIREMENTS:**  
 REQUIRED : 1 - 96 CONTAINER FOR 20 UNITS OR FRACTION THEREOF.  
 RECOMMENDED : 2 - 96 CONTAINERS MINIMUM

**NOTES:**

1. ALL SLOPES MUST MEET FEDERAL ADA AND NC STATE STANDARDS, WHENEVER CONFLICTS EXIST, THE MORE RESTRICTIVE PROVISION SHALL APPLY.
2. ACCESS FOR CITY REFUSE COLLECTION SHALL BE UNOBSTRUCTED BY PARKING OR ANY OTHER FORM OF TEMPORARY OF PERMANENT OBSTRUCTIONS.

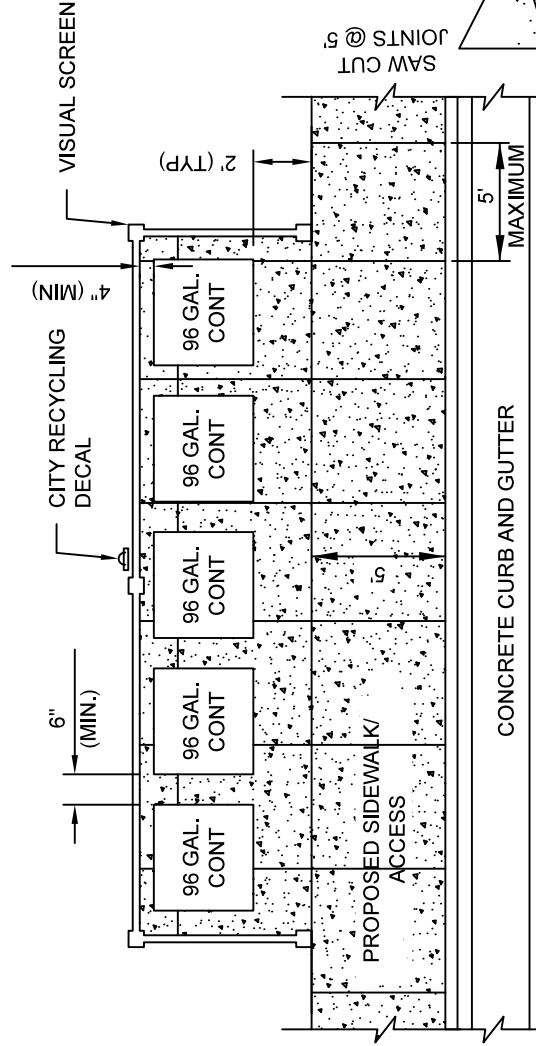

**PLAN VIEW**

**ISOMETRIC VIEW**

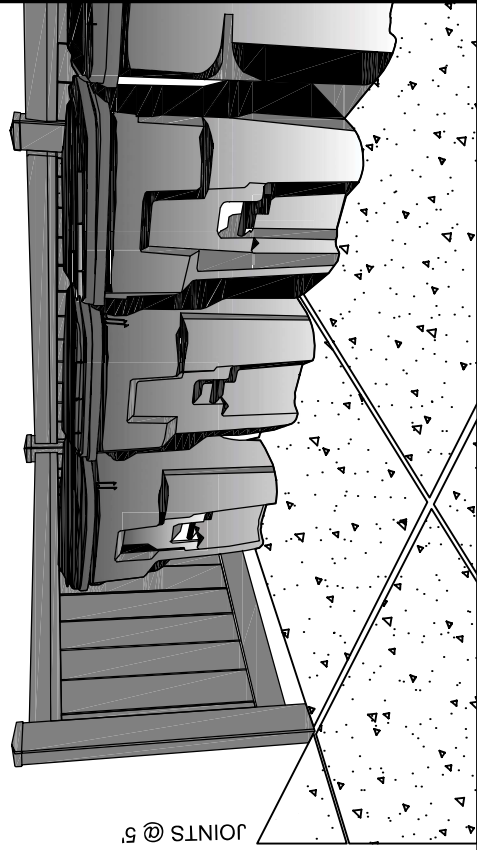

ENGINEERING DEPARTMENT  
 1500 Beatty Street  
 Greenville, North Carolina 27834

**CITY OF GREENVILLE, N.C.**  
[www.greenvillenc.gov](http://www.greenvillenc.gov)

Rev.	Date	Description	Approved
1	9/1/23	APPROVAL	L. KIRBY

**RECYCLING CENTER**

Scale: not to scale	Sheet #: 1 of 1	Detail #: 415.02
------------------------	--------------------	---------------------

